

DISPLAY | Serve Over Counters

REFRIGERATED DISPLAY CABINETS ▶ SERVE OVER COUNTERS ▶ VENTILATED

WST 100



40 mm	M2 -1°C +7°C	F ENERGY CLASS	3 +25°C/60RH
LED			GAS R290

DETAILS

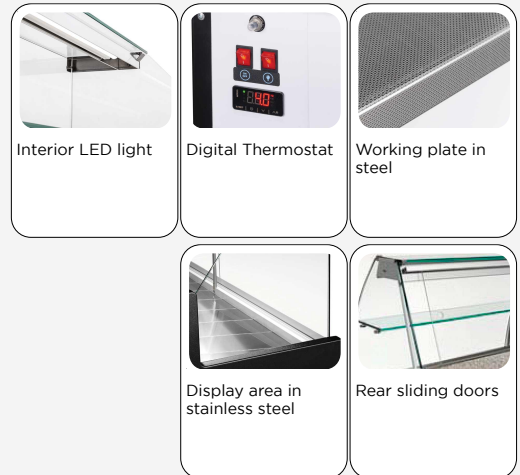

GENERAL FEATURES

- Serve-over refrigerated counter
- Working plate in steel
- Display area in stainless steel
- Ventilated Cooling
- Evaporator with anti-corrosion treatment
- Automatic compressor cycle defrost
- Digital thermostat with "opening door" and "High temperature" alarm
- Cap in vertical tempered glass
- Glass intermediate shelf not refrigerated
- Interior LED light (with independent switch)
- Insulated tank with water base foaming
- N.4 Adjustable feet
- Energy efficiency class: F

TECHNICAL SPECIFICATIONS

Capacity	86 L
Temperature	M2 (-1°C-+7°C)
Consumption	4.99 kWh/24h
Rated Power	310 W
Noise level	63 dB(A)
Net Weight	130 Kg
Gross Weight	160 Kg
External Dimensions (WxDxH mm)	1040x910x1290
Internal Dimensions (WxDxH mm)	900x390x220
Packaging dimensions (WxDxH mm)	1100x1050x1130
Loading quantities 20'/40'/40'HQ	20/44/44

PRODUCT DIMENSIONS

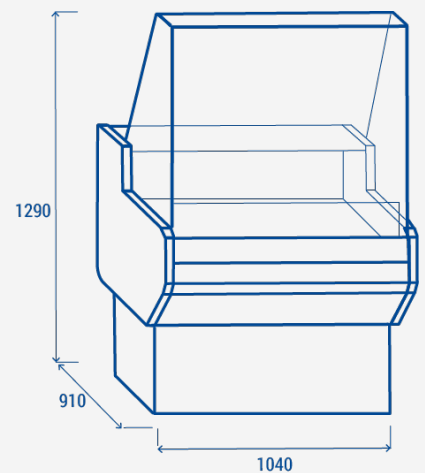

CERTIFICATION

CE RoHS

